

StoneFlower print head

for deposition of clay and pastes

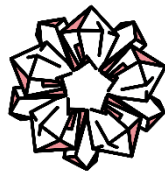

User Manual

Eching, 2018

Contents

Disclaimer	4
Intended use.....	4
Overview.....	5
Specifications	6
Printing.....	6
Software	6
Electrical	6
Installation.....	7
Mounting.....	7
Small bronze nozzles	8
Wiring	9
Start printing.....	10
Printing	11
Troubleshooting.....	12
EC Declaration of conformity	14

Disclaimer

Please read and understand the contents of this installation and user manual. Failure to read the manual may lead to personal injury, inferior results or damage to the product and/or 3D printer. Always make sure that anyone who uses the product knows and understands the contents of the manual.

The conditions or methods used for assembling, handling, storage, use or disposal of the device are beyond our control and may be beyond our knowledge. For this and other reasons, we do not assume responsibility and expressly disclaim liability for loss, injuries, damage, or expense arising out of or in any way connected with the assembly, handling, storage, use or disposal of the product.

The information in this document was obtained from sources which we believe are reliable. However, the information is provided without any warranty, express or implied, regarding its correctness.



CAUTION: The print head has moving parts that can cause injury. Never reach inside of the print head while it is in operation.



CAUTION: Never connect or disconnect print head to the 3d printer when that is powered. Connection of the motor to powered electronic circuits may irreversibly destroy them.



CAUTION: The print head is not food grade.

Intended use

StoneFlower print head is designed and built for dispensing and deposition of clay and porcelain within a commercial/business environment, being installed in compatible desk top 3d printer. Print head is precise, safe and salient. It is perfect for prototyping and small serial production of ceramic wares, sculptures, architectural models etc. from clay/porcelain of high viscosity that provides good mechanical stability to complex shapes upon printing.

Although we achieved a very high standard in the reproduction of 3D models with the print head, the user remains responsible to qualify and validate the application of the printed object for its intended use. While we do not put any limitations on the choice of materials for extrusion with the KIT, we recommend to use finely dispersed clays and porcelains of moderate viscosity. Using too viscous material lead to a large loads on the motor and accelerated wear of the components. The user remains responsible to the control of the content of material and absence of any components, which may dissolve, corrode, or damage the components of the print head upon extrusion.

Overview

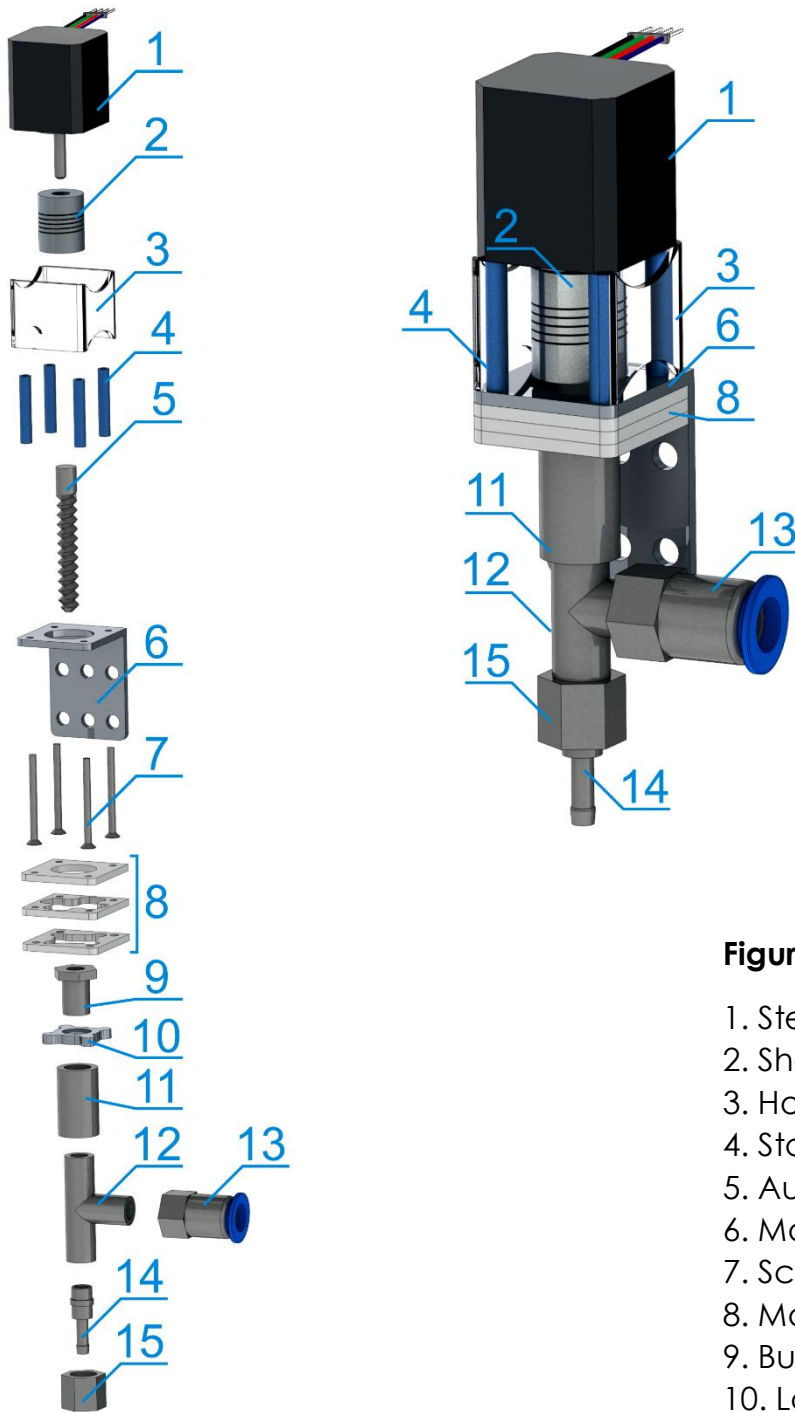

Figure 1.

- 1. Stepper motor
- 2. Shaft coupling
- 3. Housing
- 4. Standoffs
- 5. Auger screw
- 6. Mount (aluminum)
- 7. Screws
- 8. Mount (POM)
- 9. Bulkhead fitting
- 10. Lock (POM)
- 11. Fitting
- 12. Tee fitting
- 13. Push-in connector
- 14. Nozzle
- 15. Sleeve nut

Specifications

Dimensions	WxDxH = 36x40x180mm
Inlet	plug-in connector, 12mm
Nozzle adapter	1/4inch x M6
Nozzle diameters	1.0, 2.0, 2.5mm
Materials	nickel-plated brass, stainless steel, aluminum, POM (mount), bronze (nozzle)
Weight	450g

Printing

Recommended rotation speed	1-3 Hz
Layer resolution	0.3 ... 1.5mm
Print speed	30mm/s ... 100mm/s

Software

All slicing software is compatible: Cura 3D, Repetier, Slic3r, Simplify3D etc.
Use right nozzle diameter in the slicing software to get better results.

Electrical

Nema14 motor	14HS13-0804S, 2 phase, 4 wires
Holding Torque	18Ncm
Rated current/phase	0.8A DC
Phase resistance	6.8Om
Rated voltage	5.4V DC
Phase inductance (1Khz)	10mH

If the print head is used with the materials other than wet clay/porcelain, please check chemical compatibility with the materials of the print head first.

Conditions

Ambient operation temperature	15 ... 32 °C
Storage temperature	0 ... 32 °C

Installation

Mounting

To mount the print head into your printer you can use universal Pololu bracket (preinstalled) or universal mounting plate (supplied with the print head).

Mounting plate can be milled, sawed, drilled or laser-cut before installation according to the structure of your printer. Installation of the plate is shown below:

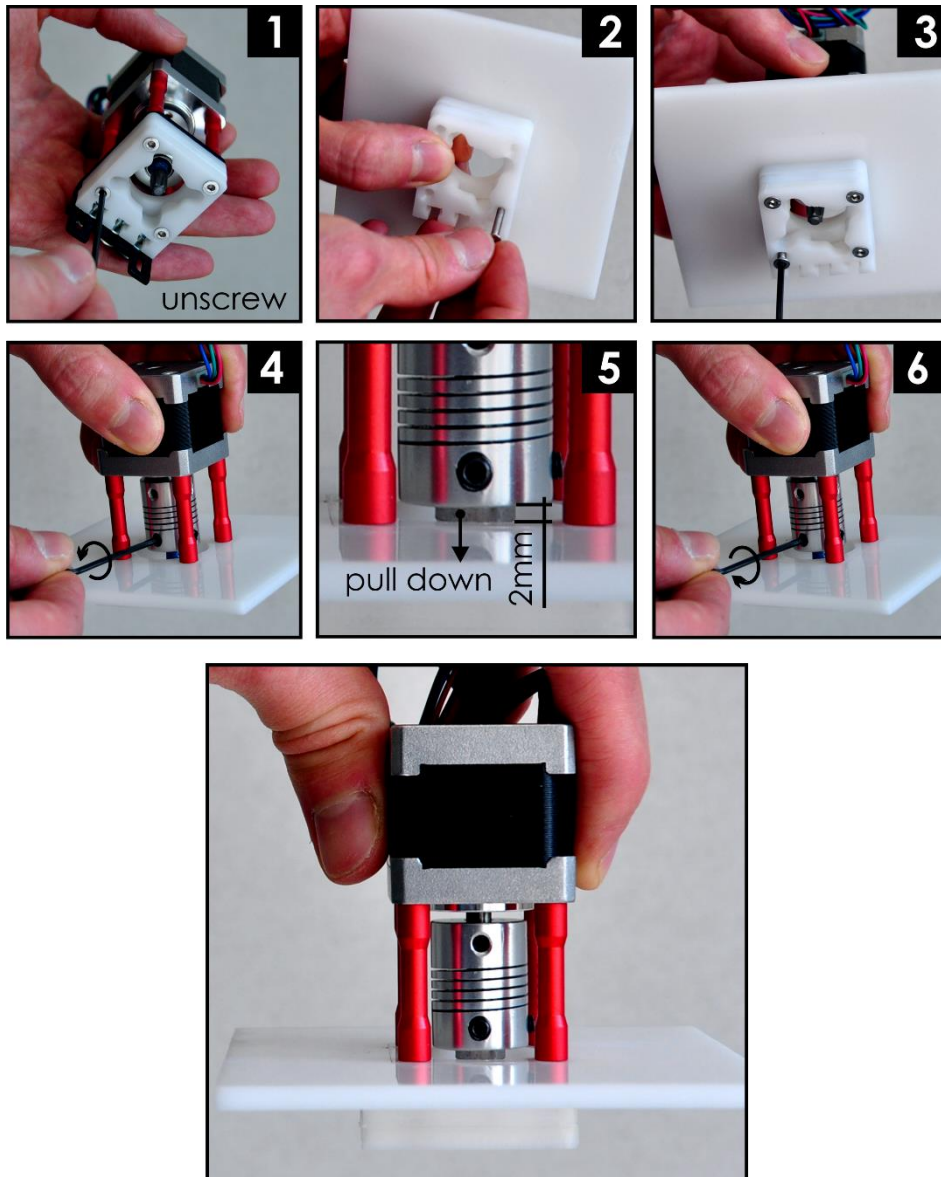

Steps:

1. Unscrew four screws, holding the mount.
- 2-3. Replace Pololu bracket with the preliminary modified mounting plate and install screws back.
4. Loose bottom screws of the shaft coupling
5. Pull HEX magnetic coupler by 2mm down.
6. Tighten the screws of shaft coupling.

Small bronze nozzles

Bronze nozzles of different diameters are installed using small adapter, as shown below.

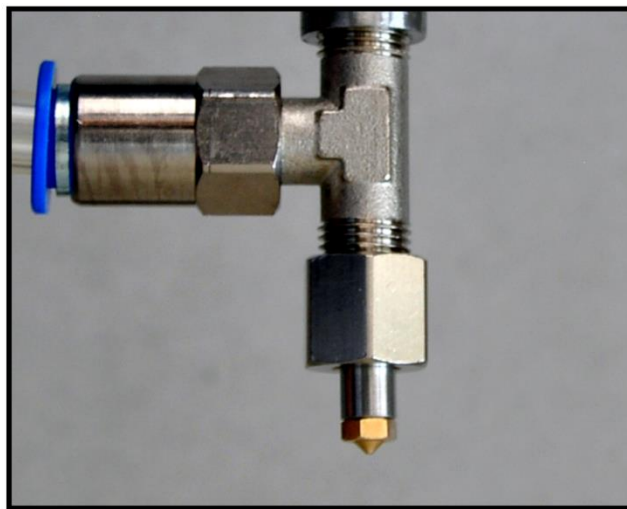
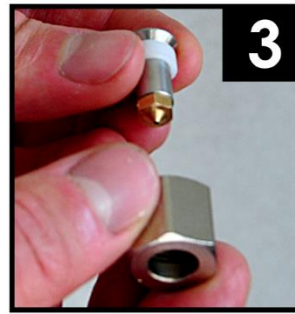
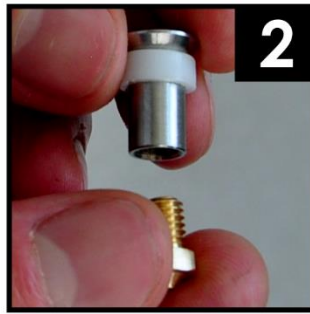

Wiring



CAUTION: Printer and motor drivers have to be switched off before wiring. Connection or disconnection of the print head from powered electronics will destroy it.



CAUTION: Do not start wiring before mounting the print head

NOTE Correctly installed extruder must rotate counter-clockwise when feeding clay (looking from above)

Connect wires of the stepper motor to the plug-in connector of the board. For color code see specifications/electrical/wiring diagram below. Adjust the stepper motor driver to hold the torque but don't get too hot. Use values of rated current and voltage as a starting point.

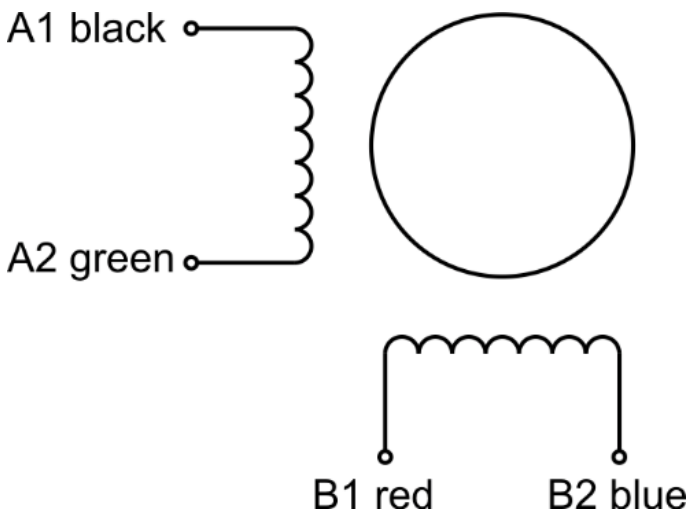

Start printing

Before printing the body of the extruder have to be disjoined from the mount. Auger screw and nozzle have to be removed from the extruder. The motor and clay container have to be properly installed, and ready for printing.

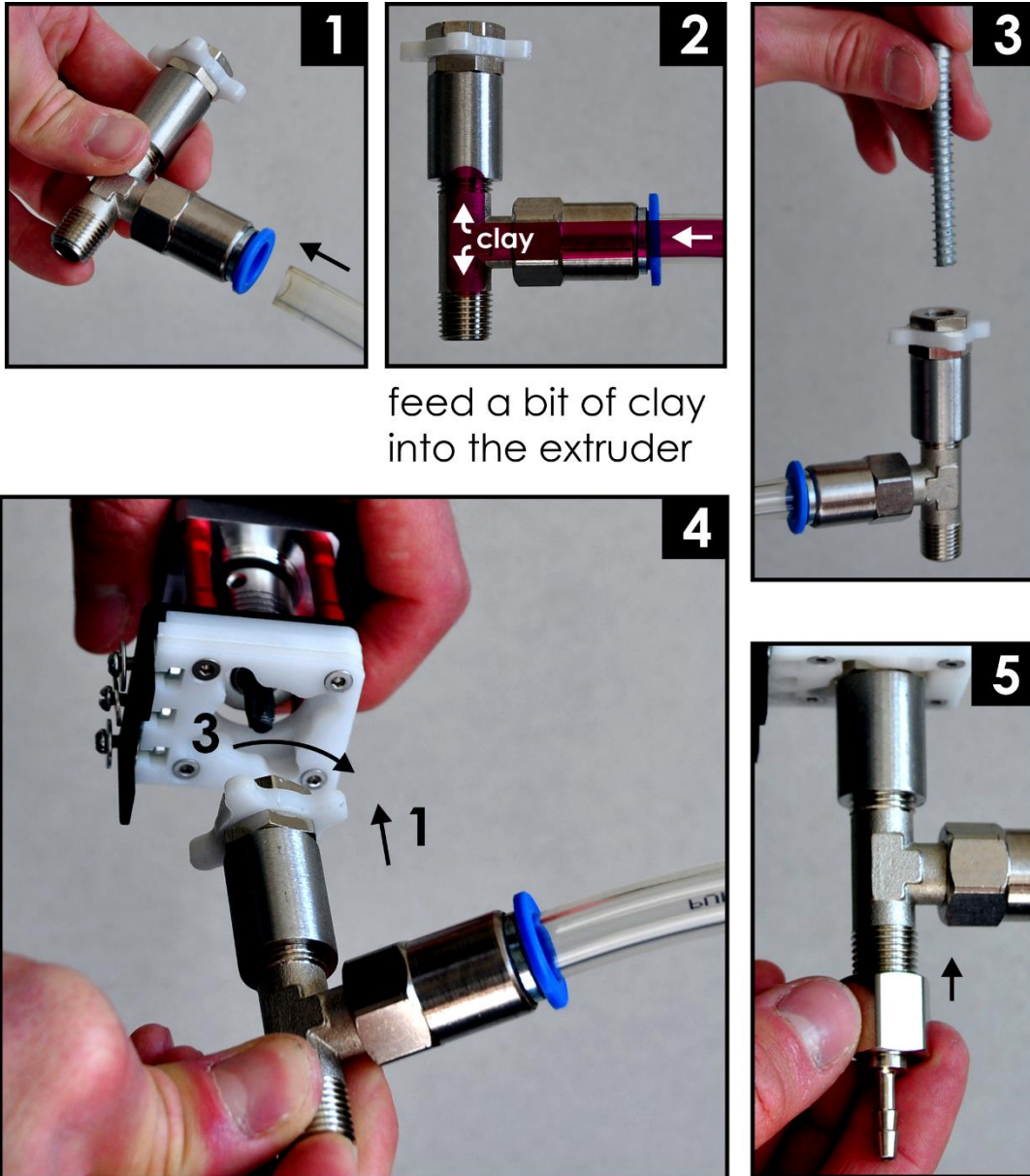

feed a bit of clay
into the extruder

1. plug in
2. align the screw and the bit
3. turn extruder in the lock CW by 30°

Steps:

1. Connect the pipe for clay (not included). **We recommend high pressure pneumatic PU pipes 12x8mm (external x internal diameter), but not PVC or PTFE**
2. Feed a bit of clay into the extruder, as shown in the figure
3. Insert the screw
4. Mount the extruder body
5. Install the nozzle

Printing

Printing quality significantly depend on the type of the clay, its viscosity, and printing speed. We recommend to start with quite diluted fine clays, or porcelain, and gradually increase viscosity, if necessary.

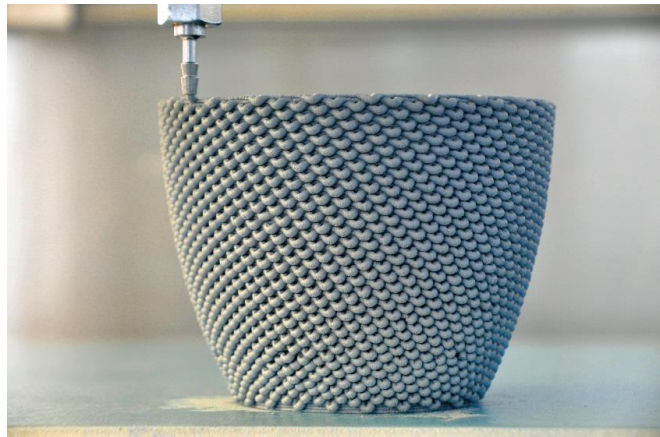

Optimal rotation speed of the extruder is about 1 to 3 rotations per second. Smaller nozzles require more diluted clay. Typically, one has to add from 7 to 15% of water (by weight) to normal clay for better results. One can add about 3 to 5% of ethanol (or bioethanol) to accelerate drying of the prints, and improve their mechanical stability. Please carefully read and follow all precautions and safety rules, when using ethanol.

If you just start printing, or paused it for few tenth of minutes, extrude a bit of clay to restore clay pressure right before printing.

The clay tend to dry in the contact with air. This may clog the nozzle (and especially nozzles of small diameters). When printing is paused, cover the nozzle with a wet cloths and plastic bag to prevent drying. Extrude a bit of clay before printing.

If the nozzle is clogged, unscrew this, and rinse with water. Cleaning of mounted nozzle without rinsing may cause repetitive clogging.

Clean and dry the extruder right after use. Long exposure to the moisture can corrode the Auger screw, and other components of the print head.

Do not use too thick clay. Despite rough surface of the prints, this causes elevated power consumption, overheating of the motor, non-uniform elevation of clay viscosity in the extruder, and unstable printing.



Escape pollution of the motor with clay.
This will destroy the motor.

Troubleshooting

Problem	Possible reason and solution
Extruder rotates, but does not feed clay	Not enough pressure at the inlet of extruder. Check your clay feeding system.
Clay comes over the top of extruder	Auger screw does not moves or nozzle is clogged. Check connection of the screw, clean the nozzle. If this does not help, clean the whole extruder, and refill this again with new portion of clay. Be sure that clay does not contain large particles. Reduce clay viscosity or use larger nozzle diameter, when nothing else helps.
Regular clogging	Check dispersity of the clay. Rinse extruder from dry clay.
Pollution of the clay, darkening upon burning	Do not run the extruder for a long time without clay flowing through. This causes wear of extruder, and pollution of the clay with metallic powder. Extrude polluted clay before printing.
Printed object bears non-desired periodic pattern (oscillating clay feeding)	<ol style="list-style-type: none">1. Backslash of the extruder. Tighten the screws of the mount. Properly lock extruder in the mount.2. High tension of the pipe. Reduce the distance between barrel with clay and the print head. Use longer pipe. Flexibly mount the barrel.3. Screw is too close to the nozzle and periodically blocks this. Move the screw a bit up, by moving magnetic HEX bit, as shown in section Installation/Mounting, Steps 4...6.
Amount of extruded clay goes down with time	Gradual loose of the clay pressure due to compression. Dilute clay.
Rough surface of the print	Dilute clay
Poor mechanical stability of the prints	Try to dry prints with cold air flow. Hot air is undesirable: this reduces viscosity of the clay, and also may damage plastic parts of the print head. Admix ethanol to clay. Add less water.
Noise and under extrusion	Check that the Auger screw, the bit, and the HEX connector are properly aligned and connected. Clean the

Jigging of the motor, noise,
underextrusion

head of the screw, and tip of the bit if
necessary.

Check connection of the motor to the
board. If this is not the reason of the
problem, this can be caused by the
loss of steps. Reduce the printing
speed, clay viscosity, adjust (increase)
the current on the stepper motor driver.
Keep eye on the motor temperature.
The motor must not get hot!

EC Declaration of conformity

Product: Add-on for 3D Printer
Models: StoneFLower Ceramic 3D Printing KIT
Basic/Standard/Pro
StoneFlower print head
Manufacturer: Anatoly Berezkin,
Schillerstr. 28,
85386 Eching,
Germany
+49(0)16095972706
info@stoneflower3d.com

Year of affixing CE marking: 2018

I hereby declare under my sole responsibility that the products above are in compliance with the essential requirements of the Machine Directive (2006/42/EU), Electromagnetic Compatibility Directive (2014/30/EU), WEEE (2012/19/EU), RoHS II (2011/65/EU) and REACH (1907/2006/EU) by application of:

Standard:

EN 60950-1: 2005 (second edition) + Am1:2009 + Am2:2013
EN 55014-1:2006 + A1:2009 + A2:2011
EN 55014-2:1997 + AC:1997 + A1:2001 + A2:2008
EN 62233:2008 + AC:2008

Title:

Electrical Safety
Radiated emissions class A
Immunity
EMF related to human body

The technical documentation is kept at the Manufacturer's address.

For electrical safety aspects reference is also made to the EC-Conformity Declaration for the power supplies.

Anatoly Berezkin



Date of issue: 22 March 2018

Place of issue: Eching